

**FRIENDSHIP PUBLIC CHARTER SCHOOL**  
**REQUEST FOR PROPOSALS FOR**

**RFP — Professional Demolition Services and School building façade finishing work**

Friendship is soliciting proposals and qualification statements from parties having specific interests and qualifications in the areas identified in this solicitation. A selection committee will review and evaluate all qualification statements and proposals and may request that the bidders make oral presentations and/or provide additional information. The selection committee will rely on the qualification statements, proposals, additional information if provided and oral presentations if made, in the selection of finalists and, therefore, bidders should emphasize specific information considered pertinent to this solicitation and submit all information requested.

Interested parties shall submit their response to this RFP by mailing 3 sealed hard copies, and 1 electronic copy. The proposal should be sent to: [procurementinquiry@friendshipschools.org](mailto:procurementinquiry@friendshipschools.org). The hard copy RFP responses must be clearly marked “RFP — To provide **Professional Demolition Services and School building façade finishing work** to:

**Procurement Inquiry**  
Friendship Public Charter School (FPCS)  
1400 1st Street, NW Suite 300  
Washington, DC. 20001

**By no later than 4pm, Monday, October 28, 2019**

*You must sign below in INK; failure to sign WILL disqualify the proposal.*

Company Name: \_\_\_\_\_

Company Address: \_\_\_\_\_

City, State, Zip Code: \_\_\_\_\_

Taxpayer Identification Number (T.I.N.): \_\_\_\_\_

Telephone: \_\_\_\_\_ Fax: \_\_\_\_\_

Email: \_\_\_\_\_

Print Name: \_\_\_\_\_ Signature: \_\_\_\_\_

*Your signature attests to your proposal to provide the goods and/or services in this proposal according to the published provisions of this Request for Proposal unless modifications or alterations are clearly noted in your proposal submission.*

*Friendship Public Charter School Inc. (“Friendship”) reserves the right to reject any and all qualification statements, to cancel this solicitation, and to waive any informalities or irregularities in procedure.*

## TABLE OF CONTENTS – REQUEST FOR PROPOSAL PACKAGE

The items below represent components which comprise this Request for Proposal (RFP) package. Proposers are asked to review the package to be sure that all applicable parts are included. It is the Proposers responsibility to be thoroughly familiar with all Requirements and Specifications. Be sure you understand the following before you return your proposal packet.

1. **Cover Sheet:** Your company name, address, and your signature (**IN INK**) should appear on this page
2. **Table of Contents:** Identifies the order in which the information appears in the document.
3. **General Requirements:** You should be familiar with all of the General Requirements.
4. **Special Requirements/Instructions:** This section provides information you must know in order to make a complete and proper proposal.
5. **Specifications:** This section contains the detailed description of the products/services sought by Friendship Public Charter School.
6. **Attachments**
  - a. Proposal Requirement
  - b. Insurance Coverage Requirements
  - c. Financial Statements
  - d. Proposed Exceptions, Alterations, Additions, or Modifications to RFP (if any)

## GENERAL REQUIREMENTS

### ACCESS TO RECORDS

Proposer may be required to allow duly authorized representatives of FPCS access to contracts, books, documents, and records necessary to verify the nature, extent, and cost of services provided by the Proposer.

### AWARD

FPCS reserves the right to reject any and all proposals, and reserves the sole right at its discretion to accept any proposal(s) it considers most favorable to the interest of FPCS and waive any and all minor irregularities in any proposal(s). FPCS further reserves the right to reject any proposal(s) and seek new proposals through the issuance of a new or amended RFP if such action is deemed in the best interest of FPCS.

### OFFER COMPLETION

Completed proposal(s) must be sent to **Procurement Inquiry, 1400 1<sup>st</sup> Street, NW, Washington DC 20001**. An authorized company representative should sign the Cover Sheet. Completion of these forms is intended to verify that the proposer has submitted the proposal, is familiar with its contents, and has submitted the material in accordance with all requirements.

The submission of a response shall be prima facie evidence that the Proposer has full knowledge of the scope, nature, quantity, and quality of work to be performed, the detailed requirements of the project, and the conditions under which the work is to be performed.

All terms, conditions, specifications, stipulations and supplier requirements stated in the RFP, any attached Appendices to the RFP, and any and all Addenda issued shall become part of the contract entered into between FPCS and the Proposer.

### **OFFER RETURNS**

Proposers must return completed proposals by date stated above. Late proposals will not be accepted. It is the responsibility of the responding Proposer to assure that the response is received prior to the date/time indicated on the Cover Page of this package.

### **CONTRACT RENEWALS**

Renewals may be made **ONLY** by written agreement between FPCS and the Proposer. Any price escalations are limited to those stated by the Proposer in the original proposal.

### **DISQUALIFICATION OF PROPOSER**

Upon signing this offer document, a Proposer certifies that the proposal has not violated the antitrust laws of this state, Business & Commerce Code, or the federal antitrust laws, and has not communicated directly or indirectly the proposal made to any competitor or any other person engaged in such line of business. Any or all proposals may be rejected if FPCS believes that collusion exists among the proposers. Proposals in which the prices are obviously unbalanced may be rejected.

### **EVALUATION**

In evaluating the proposals submitted, FPCS will apply the “Best Value” process in selecting the Proposer to be awarded a contract for this project. **Purchase price is not the only criteria that will be used in the evaluation process.** The selection process will include, but not be limited to, the following considerations:

1. The purchase price.
2. The Proposer’s overall experience, reputation, expertise, stability and financial responsibility.
3. The quality and range of goods and/or services the firm proposes to provide.
4. The extent to which the goods and/or services meet FPCS needs.
5. The Proposer’s past relationship with FPCS.
6. The ability to provide service in a reliable, expedient and efficient manner.
7. The total long-term cost to FPCS to acquire the Proposer’s goods or services.
8. Any other relevant factor(s) specifically listed in the request for proposals.

All proposals must be valid for a minimum period of one hundred-twenty (120) days from the due date of this RFP. Proposers shall furnish in a timely manner to FPCS such additional information as FPCS may reasonably require.

FPCS reserves the right to contact references from the Proposer’s client list, or any other persons considered relevant by FPCS.

All costs associated with the project must be enumerated in the proposal. Any costs associated with the project not explicitly enumerated and discussed in the proposal will not be honored. Contract prices and terms are to remain firm through project completion. The Proposer shall

provide information on their standard fee arrangement for any goods and/or services proposed, and any discounts offered.

### **DOCUMENT INTERPRETATION**

In the event of any conflict of interpretation of any part of this overall document, the interpretation of FPCS shall govern consistent with the laws of the District of Columbia. Wherever the term "Proposer" is used throughout the RFP, it includes the Proposer's agents, employees, directors and/or assigns even if not specifically delineated.

### **HOLD HARMLESS AGREEMENT**

The successful Proposer(s), its agents, employees (paid or volunteer), directors and/or assigns shall indemnify, hold harmless, and defend FPCS, its directors, officers, and employees (paid or volunteer) from and against any and all claims, demands, causes of action of whatever kind or nature arising out of error, omission, misrepresentation, negligent act, conduct or misconduct of the Proposer and its agents, employees(paid or volunteer), directors and/or assigns in the provision of goods or the performance of services arising out of the preparation of this proposal and execution and performance of any contracts resulting there from. Such indemnification shall also include reasonable attorneys' fees, court costs, and expenses.

### **INSPECTIONS**

FPCS reserves the right to inspect any item(s) or service location for compliance with specifications, requirements, and the needs of FPCS. If a Proposer cannot furnish a sample of a proposed item, where applicable, for review, or fails to satisfactorily show an ability to perform, FPCS can reject the proposal as inadequate.

### **TESTING**

FPCS reserves the right to test equipment, supplies, materials and goods proposed for quality, compliance with specifications and ability to meet the needs of FPCS. Demonstration units must be available for review. Should the goods or services fail to meet requirements and/or be unavailable for evaluation, the proposal is subject to rejection.

### **INVOICES AND PAYMENTS**

The Proposer who is awarded the contract is required to send all invoices to FPCS's reference point of contact and to **Accounts Payable 1400 1st Street NW Washington DC 20001**. Invoices shall be provided to FPCS in a timely manner. The Proposer who is awarded the contract is required to invoice FPCS within 30 days of providing goods and/or services to FPCS.

In the event FPCS is presented with invoices, statements, reports, etc. that are incomplete, or inaccurate, FPCS may be required to perform substantial research which could result in delay of payment. FPCS will not be responsible for any interest charges and/or late fees as a result of delayed payment due to time delays caused by inadequate, incomplete, or inaccurate information provided in invoices.

### **PRICING**

Prices for all goods and/or services shall be negotiated to a firm amount for the duration of the contract or as agreed to in terms of time frame and/or method of determining price escalations, if

any by Proposer. All prices and methods of determining prices must be written in ink or typewritten. Where unit pricing and extended pricing differ, unit pricing prevails.

### **SUPPLEMENTAL MATERIALS**

Proposers are responsible for including all pertinent product data in the returned offer package. Literature, brochures, data sheets, specification information, completed forms requested as part of the offer package and any other facts which may affect the evaluation and subsequent contract award should be included. Materials such as legal documents and contractual agreements, which the Proposer wishes to include as a condition of the proposal, must also be in the returned proposal package. Failure to include all necessary and proper supplemental materials may be cause to reject the entire proposal.

### **TAXES**

FPCS is exempt from federal, state and local taxes. In the event that taxes are imposed on the goods or services purchased, FPCS will not be responsible for payment of the taxes. The Proposer awarded the contract shall absorb the taxes entirely. Certificates of exemption will be furnished upon written request to FPCS.

### **TERM CONTRACTS**

Any contract which results from this RFP shall run for three-year period with an exclusive option by FPCS to renew on an annual basis. There is to be an additional 90-day transitional period added to the end of the contractual agreement which may be exercised at the option of FPCS. The contractual prices, terms and conditions are to remain in force during the transitional period.

The successful Proposer, as determined by FPCS, shall be required to execute a contract to furnish all goods and/or services and other deliverables required for successful completion of the proposed project. No Proposer shall obtain any interest or right in any award until FPCS has executed a contract, and any such interest and rights shall be subject to the terms and conditions as contained in such contract.

The successful Proposer may not assign, sell, or otherwise transfer its interest in the contract award or any part thereof, without prior written consent from the FPCS.

### **QUANTITY**

There is no guaranteed amount of business, expressed or implied, to be purchased or, contracted for by FPCS in the initial maximum 1-year contract term or in subsequent renewals, which may or may not be negotiated and agreed to by FPCS with any proposer(s). However, the Proposer(s) awarded the contract shall furnish all required goods and/or services to FPCS at the stated price, when and if required.

### **CONTRACT TYPE**

The preferred contract type to be awarded is a fixed fee contract. However, if a Proposer has reason to believe a better (more cost effective) method is practical, then the Proposer is encouraged to offer that better pricing option as an alternative in its submitted proposal. FPCS will consider that type of contract as it compares with other recommended contract options. The contract type providing the best value, over the longest period of time is what FPCS seeks.

Proposers are required to provide FPCS with a menu of any optional services offered. Each service must be priced separately and independent of any other services offered or rendered.

### **TERMINATION**

FPCS reserves the right to terminate the contract without cause with 60 days' prior written notice for convenience and with 30 days' prior written notice for cause, if Proposer breaches any of the terms therein, including warranties of proposer or if the proposer becomes insolvent or commits acts of bankruptcy. Such right of termination is in addition to and not in lieu of any other remedies which FPCS may have in law or equity. Cause may be construed as, but not limited to, failure to deliver the proper goods and/or services within the proper amount of time, and/or to properly perform any and all services required to FPCS's satisfaction and/or to meet all other obligations and requirements.

If the Proposer breaches any provision of the proposal stipulations, becomes insolvent, enters voluntary or involuntary bankruptcy, or receivership proceedings, or makes an assignment for the benefit of creditors, FPCS will have the right (without limiting any other rights or remedies that it may have in the contract or by law) to terminate any contract with 30 days' prior written notice to the Proposer.

FPCS will then be relieved of all obligations, except to pay the reasonable value of the supplier's prior performance (at a cost not exceeding the contract rate). The Proposer will be liable to FPCS for all costs exceeding the contract price that FPCS incurs in completing or procuring the service as described in the proposal. FPCS's right to require strict performance of any obligation in this contract will not be affected by any previous waiver, forbearance, or course of dealing.

### **TRANSITION**

Once an executed contract with the Proposer terminates for any reason, FPCS reserves the right to have a period of time to transition the contracted goods and/or services provided to FPCS by the Proposer to a new provider. During this transition period, FPCS will pay for these goods and/or services to the provider at the negotiated rate(s) in existence at that time. FPCS further reserves the right to establish the length of the transition period and communicate this transition time period to the provider; however, such transition period shall not exceed 180 days.

### **FUNDING OUT OPTION**

Any contract resulting from this RFP is contingent upon the continued availability of budget appropriations and is subject to cancellation, without penalty to FPCS, either in whole or in part, if funds are not appropriated by the FPCS Board of Directors, or otherwise not made available to FPCS. All outstanding invoices will be paid upon cancellation.

### **WARRANTIES**

Proposers shall furnish all data pertinent to warranties or guarantees, which may apply to items in the proposal. Proposers may not limit or exclude any implied warranties.

## **ASSOCIATION**

Proposers may not use the FPCS official logo(s), or any phrase associated with FPCS, without the written permission from FPCS.

## **EXCEPTIONS, ALTERATIONS, ADDITIONS AND MODIFICATIONS**

If any exceptions, alterations, additions, or modifications are submitted by Proposer to any portion of this RFP, the Proposer must clearly indicate the exceptions, alterations, additions and modifications and include a full explanation as a separate attachment to the proposal. The failure to identify exceptions, alterations, or modifications will constitute acceptance by the proposer of the RFP as proposed by FPCS. FPCS reserves the right to reject a proposal containing exceptions, alterations, additions, or modifications.

## **PROPOSAL PREPARATION COSTS**

All costs related to the preparation and submission of this proposal shall be paid by the Proposer. Issuance of this RFP does not commit FPCS, in any way, to pay any costs in the preparation and submission of the proposal, nor does the issuance of the RFP obligate FPCS to award a contract or purchase any goods and services stated in the RFP.

## **RETENTION OF PROPOSAL DOCUMENTATION**

All proposal materials and supporting documentation that is submitted in response to this proposal becomes the permanent property of FPCS.

## **MODIFICATION/WITHDRAWAL OF PROPOSAL**

Proposals may be modified in writing at any time prior to the due date. Proposals may be withdrawn in writing, by facsimile written transmission, or in person before the response date.

## **SPECIAL REQUIREMENTS/INSTRUCTIONS**

### **EVALUATION AND AWARD**

This RFP in no manner obligates FPCS to the eventual rental, lease, and purchase, etc. of any equipment or service described, implied or which may be proposed, until confirmed by a written contract. Progress toward this end is solely at the discretion of FPCS and may be terminated at any time prior to the signing of the contract. FPCS may initiate discussions with supplier personnel authorized to contractually obligate the supplier. Discussions will develop into negotiating sessions with the successful Proposer(s).

If FPCS is unable to agree to contract terms, FPCS reserves the right to terminate contract negotiations with a Proposer and initiate negotiations with another Proposer. FPCS reserves the right to select services and products from any number of Proposers if in its sole discretion it is in the best interest of FPCS to do so. Evaluation will consider the proposal(s) best meeting the needs and requirements of FPCS and such evaluation and determination of best value shall be solely at the discretion of FPCS.

**Purchase price is not the only criteria that will be used in the evaluation process.**

Submission of a proposal implies the Proposer's acceptance of the evaluation criteria and all other terms and conditions as set forth in this RFP as well as the Proposer's recognition that subjective judgments can and will be made by those individuals evaluating proposals.

**FPCS RESERVES THE RIGHT TO AWARD THE CONTRACT TO ONE PROPOSER/CONTRACTOR, OR MORE THAN ONE PROPOSER/CONTRACTOR IN ITS SOLE DISCRETION.**

**NON-PERFORMANCE BY PROPOSER/CONTRACTOR**

Performance, before and during the contract term, will be a major consideration of current contract award, renewals, and future award considerations. Failure to perform, in any sense relative to this contract, may result in the probation and/or termination of this agreement by FPCS on the basis of nonperformance. Nonperformance shall be determined as follows:

1. Failure to meet and maintain all qualifications required in this RFP;
2. Failure to meet required operating performance standards in the time period required and consistent with workmanlike manner. Workmanlike manner means work that is "completed in a skillful manner and is non-defective."
3. Failure to keep and maintain all required insurance coverage;
4. Failure to cure deficiencies within a reasonable amount of time as stated herein.

**INSURANCE**

All proposers must provide evidence of insurance or insurability.

**CONFLICT OF INTREST**

The prospective proposer, its agents, employees, directors and/or assigns, shall disclose any financial, business or other relationship with FPCS that may have an impact upon the outcome of this contract or potential future of the FPCS projects resulting from this effort. The prospective proposer, its agents, employees, directors and/or assigns shall also list current clients who may have a financial interest in the outcome of this contract or FPCS projects that will follow. In particular, the prospective proposer its agents, employees, directors and/or assigns shall disclose any financial interest or relationship with any company that might submit a bid on the FPCS projects. **If applicable, please complete Attachment E.**

**NON DISCRIMINATION**

The selected proposer shall comply, and shall require its agents, employees, directors and/or assigns to comply, with all applicable federal, state, and local laws, ordinances, rules, and regulations in regard to nondiscrimination in employment because of race, creed, color, ancestry, national origin, religion, sex, marital status, age, medical condition, pregnancy, disability, or other prohibited basis.



## **RFP SPECIFICATIONS**

### **Friendship PCS is seeking a vendor to supply– Professional Demolition Services and School building façade finishing work.**

**The RFP requirements are as follows:**

#### **Professional Demolition Services**

Professional demolition services for the existing 21,000 sq. ft. warehouse portion of the building located at 6130 North Capital Street, NW, Washington DC 20011, also known as the Friendship Ideal Academy warehouse. The warehouse is to be demolished and removed. The remaining building is to be temporarily waterproofed and stabilized as a building pad in preparation for the construction of an addition. Temporary erosion and sediment control measures conforming to the District's Department of Energy and Environment standards and specifications must be enacted.

1. The contractor will be responsible for all costs of transport and proper disposal of all construction debris
2. The contractor will be responsible for all temporary facilities necessary to successfully complete the project- to include, but limited to, portable restrooms, site fencing, site security, etc.
3. The contractor will be responsible for the coordination and ensuring utility disconnections.
4. No materials from the demolition project are proposed for reuse by FPCS. The contractor shall take ownership of all scrap/salvage materials and be permitted to recycle and reuse the items as desired at the contractor's risk.
5. Caution and care must be exercised to prevent damage to adjacent property, sidewalks, pedestrians, and streetscape during demolition activities.
6. An inspection for hazardous materials is being performed to identify any contamination related to lead based paint or asbestos. Contractor must be prepared to properly remove and dispose of any hazardous materials that is identified.
7. The contractor will provide information regarding the firm's safety record, and describe the specific safety measure/plan to be used for this project to protect personnel, public structure and infrastructure.
8. Contractor must provide an estimated project schedule to complete the scope of work described above.

See attached photo of warehouse site, **Attachment F**.

#### **School building façade construction finishing work**

School building façade finishing work narrative is as follows:

1. Demolish and replace existing sidewalk at drop-off parking lot with new.
2. Demolish and remove existing concrete canopy. Repair/waterproof wall area as required.
3. Demolish and replace paving at drop off parking lot.

4. Construct new open-air canopy.
5. Install decorative wood slats on existing wall under canopy, and at second level of east wing.
6. Install fabric window banners on steel frame at existing north façade window.
7. Install one new window at second level of east wing.
8. Install new messaging sign as shown.
9. Install new exterior lighting as shown on drawings.
10. Provide an estimated project schedule to complete the scope of work described above.

See attached site and building drawings for School building façade work, **Attachment F**.

**A site visit will take place on October 11<sup>th</sup> at 10:00am. Please respond with your intent to participate in the visit no later than COB on October 7<sup>th</sup> 2019. Your RSVP should be sent to: [procurementinquiry@Friendshipschools.org](mailto:procurementinquiry@Friendshipschools.org)**

### **Proposal Requirements (Attachment A)**

Proposals shall be comprehensive and include, at a minimum, the following information organized as follows in a qualification statement:

1. Clear and detailed proposed pricing for goods and or services.
2. A brief discussion of the consultant's/company's history, and services offered. Briefly state that the Proposer understands the work to be done and will make a positive commitment to perform the work within the required time period.
3. Resumes of key staff that will provide services and or training.
4. Names and contact information of at least three client references.
5. Provide proof of CBE as firms certified as CBE will receive preferential consideration. See <http://olbd.dc.gov/>
6. A proposed signed contract, which includes terms, payments and amount contract, will not to exceed.

**INSURANCE COVERAGE REQUIREMENTS (Attachment B)**

**General & Excess Liability Minimum Coverage**

General Liability:	1,000,000
Umbrella Liability:	1,000,000

\_\_\_\_\_  
Company Name

\_\_\_\_\_  
Signature of Authorized Agent

\_\_\_\_\_  
Date Signed

**FPCS will be named as additional insured on certificate of insurance if our firm or company is awarded a contract.**

**Financial Statements (Attachment C)**

Proposer should submit as Attachment C current financial statements, preferably for the past two years, which have been audited or reviewed by a Certified Public Accountant.

**Proposed Exceptions, Alterations, Additions, or Modifications to RFP (Attachment D)**

Proposer should submit as Attachment D, any and all proposed exceptions, alterations, additions, or modifications.

**ATTACHMENT E**

**CONFLICT OF INTREST DISCLOSURE**

As a prospective vendor/supplier, its agents, employees, directors and/or assigns, you shall disclose any financial, business or other relationship with FPCS that may have an impact upon the outcome of this contract or potential future of the FPCS projects resulting from this effort. The prospective proposer, its agents, employees, directors and/or assigns shall also list current clients who may have a financial interest in the outcome of this contract or FPCS projects that will follow. In particular, the prospective proposer its agents, employees, directors and/or assigns shall disclose any financial interest or relationship with a member of the school's board or leadership.

**Name of party that poses conflict**

**Relationship/Interest**

---

---

---

---

Company Name

\_\_\_\_\_  
Signature of Authorized Agent

\_\_\_\_\_  
Date Signed

Google Maps 6130 North Capitol St NW

Attach ment F  
Warehouse



Imagery ©2019 Google, Imagery ©2019 Commonwealth of Virginia, District of Columbia (DC GIS), U.S. Geological Survey, Map data ©2019 20 ft

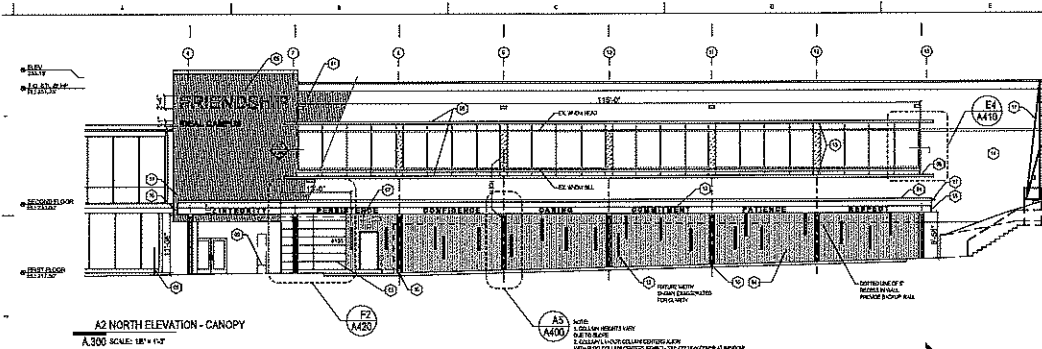

A2 NORTH ELEVATION - CANOPY  
A.300 SCALE: 1/8" = 1'-0"

NO.	KEY NOTES
01	SEE CANOPY
02	WOODER LAMINATE EXPOSED UNLESS NOTED OTHERWISE
03	TRIM AND FINISHES TO MATCH EXISTING EXCEPT WHERE NOTED OTHERWISE
04	SEE FINISHES SCHEDULE FOR FINISHES
05	SEE FINISHES SCHEDULE FOR FINISHES
06	SEE FINISHES SCHEDULE FOR FINISHES
07	SEE FINISHES SCHEDULE FOR FINISHES
08	SEE FINISHES SCHEDULE FOR FINISHES
09	SEE FINISHES SCHEDULE FOR FINISHES
10	SEE FINISHES SCHEDULE FOR FINISHES
11	SEE FINISHES SCHEDULE FOR FINISHES
12	SEE FINISHES SCHEDULE FOR FINISHES
13	SEE FINISHES SCHEDULE FOR FINISHES
14	SEE FINISHES SCHEDULE FOR FINISHES
15	SEE FINISHES SCHEDULE FOR FINISHES
16	SEE FINISHES SCHEDULE FOR FINISHES
17	SEE FINISHES SCHEDULE FOR FINISHES

PPCS - IDEAL ACADEMY  
6130 North Capital St. NW  
WASHINGTON, DC 20024

**MICHAEL MARSHALL DESIGN**

2024 ARCHITECTURAL PLAN SET  
PROJECT NO. 2024-001  
DATE: 08/20/24  
BY: MMD  
CHECKED BY: MMD

CONSULTANTS:  
STRUCTURAL ENGINEER  
MECHANICAL ENGINEER  
ELECTRICAL ENGINEER  
PLUMBING ENGINEER  
HVAC ENGINEER  
LANDSCAPE ARCHITECT  
CIVIL ENGINEER  
ENVIRONMENTAL ENGINEER  
ARCHITECTURAL INTERIOR DESIGNER  
ARCHITECTURAL EXTERIOR DESIGNER  
ARCHITECTURAL HISTORIC PRESERVATION

NO.	DESCRIPTION	DATE
1	ISSUED FOR PERMIT	08/20/24
2	ISSUED FOR CONSTRUCTION	08/20/24



EXTERIOR IMPROVEMENTS  
PROJECT NAME: MICHAEL MARSHALL DESIGN  
DRAWING NUMBER: A300  
ISSUED FOR PERMIT AND CONSTRUCTION

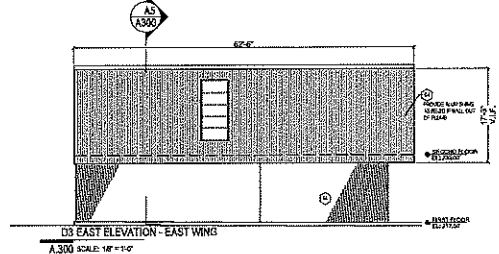

A3 EAST ELEVATION - EAST WING  
A.300 SCALE: 1/8" = 1'-0"

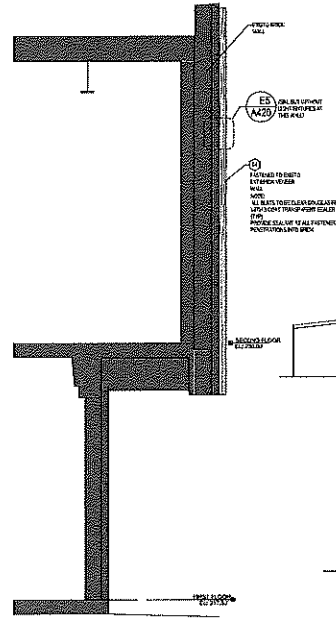

A5 EXT WALL SECTION AT EAST WING  
A.300 SCALE: 1/2" = 1'-0"

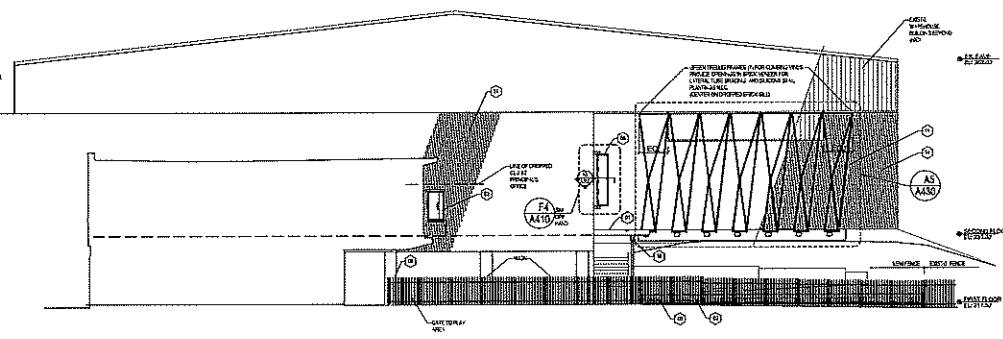

B5 PARTIAL EAST ELEVATION  
A.300 SCALE: 1/8" = 1'-0"

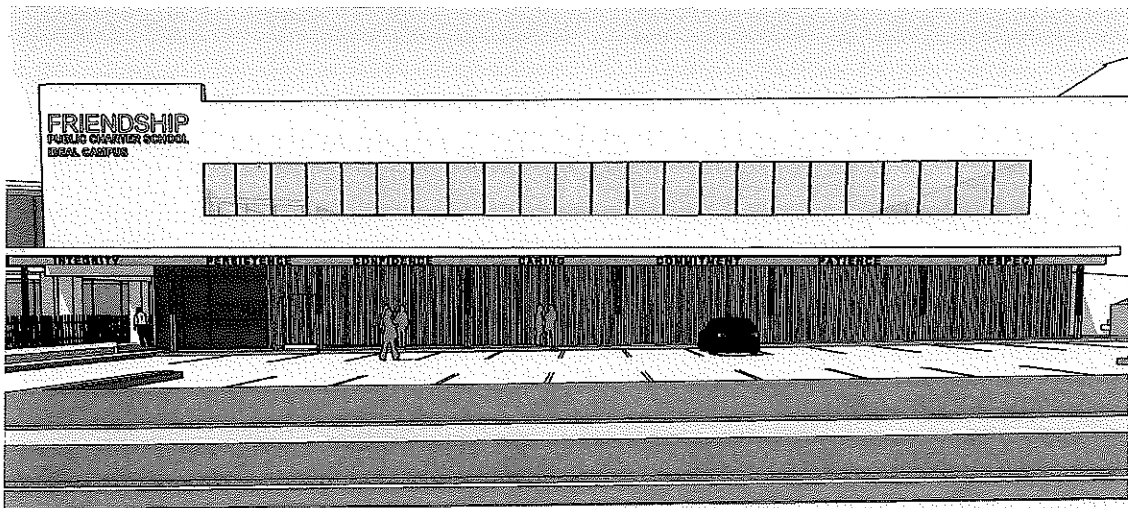

THE FRONT ELEVATION WILL GET A NEW COLLONADE WITH A NEW CANOPY OFFERING WEATHER PROTECTION. THERE ARE SEVEN STRUCTURAL BAYS FOR THE NEW COLLONADE WHICH CORRESPONDS TO THE SEVEN CORE VALUE WORDS OF FPCS. EACH BAY RECEIVES CORE VALUE SIGNAGE TO REINFORCE AT FIRST GLANCE THE SCHOOL'S MISSION. (NOTE STREET TREES NOT SHOWN HERE FOR CLARITY).







**Attachment F**  
**Site and building drawings**

For further information, contact Catherine Sanwo at [procurementinquiry@friendshipschools.org](mailto:procurementinquiry@friendshipschools.org).

**END OF FPCS RFP PACKAGE.**